

Smart Sense

ELECTRIC SENSOR S101-EL11



The S101-EL11 sensors are **intelligent transducers of digital signals into wireless data frames** collectable by the Kairo G404 gateways.

Together with the Kairo battery-free and cable-free smart sensors of the series S101-ME11 (mechanical) and S101-PN11 (pneumatic), these sensors constitute a plug&play system for the collection and analysis of production data. Any time the sensor detects a state transition of the input digital signal, the sensor transmits a unique data packet that can be received by one or more listening gateways within a range. The digital signal can be of the type PNP/dry contact (standard configuration) or NPN and the sensor can be connected in parallel to any pre-existing digital signal of a machine, equipment or workstation. The data collected by the gateway allow for real-time monitoring of process parameters such as cycle time and production efficiency.

MAIN FEATURES:

- Industrial standard M8 3 pins male connector
- Simple, inexpensive and modular solution
- Allows monitoring of any type of machine/equipment/workstation in minutes
- Efficient and robust wireless radio transmission
- Real-time monitoring of the production process and resources
- Global localization of assets
- Centralized and Cloud-based data collection, presentation and analysis
- Managing and logging of maintenance operations with automatic notification

FEATURES AND DIMENSIONS

Actuation	Digital signal PNP/Dry contact or NPN
Mass	45 g
Body material	PA66 + 30% glass fiber
IP rating	IP65
Power supply	24 Vdc
Temperature range	from -10°C to +80°C
Radio frequency	868 MHz
Signal coverage	10-80 m (depending on layout)
Certifications	EN60950-1, ETSI 301 489-1 V.2.1. ETSI 301 489-3 V.2.2.2 ETSI EN302802

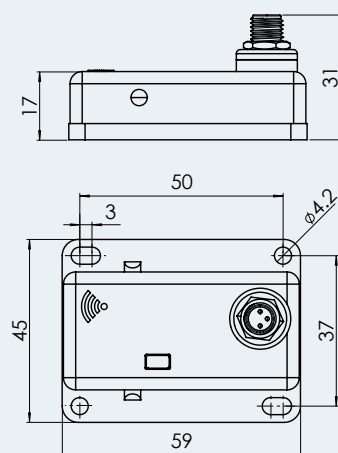

Electrical Connection Diagram

